

## Cold Neon LED (CNL) Installation Guidelines

Please note that these guidelines are guidelines only and in no way supercede any construction or installation standard. It is strongly recommended that local building and electrical codes be consulted before installation to guarantee compliance.

### 1. Transformer Requirements

Cold Neon operates on 24 Volts DC and thus a transformer and rectifier will be required. Verify that the transformer's voltage is that of the lighting. It is very important that the load be calculated carefully before selecting a transformer. For the purposes of calculating loads, Cold Neon draws different wattages depending on the colour, see table below.

Note that Cold Neon may use either a transformer with a separate inline rectifier, a DC output power supply, or an LED Driver

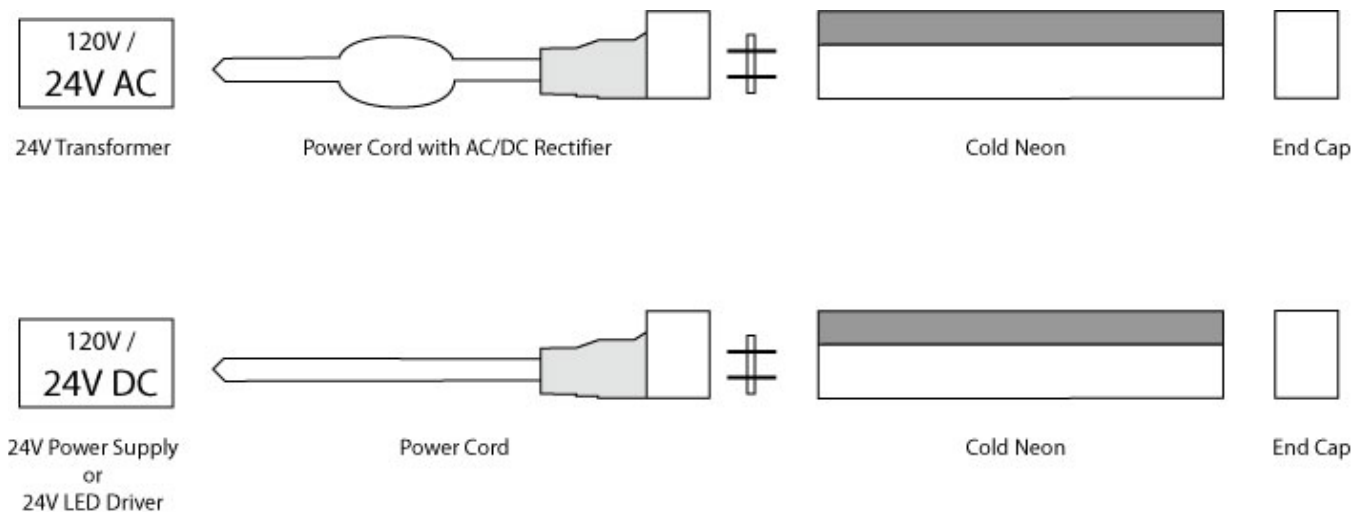

### 2. Ampacity Limitations

Please remember that this is a low voltage product and consult the appropriate section of the electrical code when selecting wire. Included with each power cord is an inline AC/DC rectifier. The maximum distance of a single run is defined by the capacity of the rectifier.

	Max Distance in Ft		
<u>W/ft</u>	<u>1.6A</u>	<u>4A</u>	<u>10A</u>
2.00	16'	40'	100'

$$\text{Current (A)} = \text{Total Wattage} / \text{Voltage}$$

### 3. Wiring Guidelines and Placement of Transformers

Consult the electrical code for details on wiring requirements. Transformers must be kept free of moisture; when installing please ensure they have adequate ventilation and are not subject to very warm or cool temperatures. Please read the manufacturers' specifications for details. For magnetic transformers we recommend that a dampening pad or device be used, as there is often some humming from the transformer. A weatherproof outdoor electrical box is strongly recommended for outdoor applications, as always please refer to the local electrical code to ensure compliance. Only magnetic transformers should be use.

#### **4. Cutting, Splicing, and Connecting**

- Only cut the Cold Neon on the designated markings points designated by scissor marks ( ✂ ).
- Cold Neon operates on DC and the polarity must be observed. If a section is not illuminating, try applying power from the other end.

##### Attaching Power Cord:

Match the two sharp pins on the connector with the two wires in the Cold Neon and insert into the wires. Note that the pins and wires are off-centre. Slide the power cord sleeve over the Cold Neon with pins protruding so that the pin ends insert into the holes provided for in the power cord coupling. Apply glue where the Cold Neon and power cord sleeve meet. If being installed outdoors, silicone or heat-shrink must be used to further seal the connections. The Cold Neon should fit snugly into the sleeve, but should fit straight. If it is not straight, the white outer layer may be trimmed back with a razor.

It is imperative that power cords with the correct size rectifiers are used; see the chart above for maximum lengths.

##### Attaching the End Cap:

Place the End Cap over the exposed end of the Cold Neon and seal with glue. If being installed outdoors, silicone or heat-shrink must be used to ensure a seal.

##### Installing the Transformer:

Use only UL/cUL/CSA or other listed transformers; class II are preferable. Power cord ends should be wired either directly into a transformer or approved junction box. It is recommended that a licensed electrician do all wiring to ensure compliance with local electrical codes.

##### Attaching L, T, X and other Junctions:

Follow the same procedure installing the L, T, X and other junctions as you would when attaching the power cords. Special care must be paid to polarity and electrical flow with the special junctions.

#### **5. Warnings**

1. Do not plug the Cold Neon in when it is wound in a coil
2. Always unplug the Cold Neon before cutting
3. Always unplug the Cold Neon before installing
4. Do not mount or support Cold Neon in a manner that can cause damage to the protective or plastic insulation. Ensure that if the jacketing is damaged the Cold Neon be powered down and replaced immediately
5. Cold Neon is water tight, but if used outdoors all connections should be insulated with silicone
6. Do not cover Cold Neon, always allow for heat dissipation and adequate ventilation. Do not use in a sealed environment.

#### **6. Lighting Installation**

##### Mounting Method 1: Aluminum Channel

This method is the most strongly recommended as it helps ensure the lighting is mounted in straight lines. Draw plumb lines to ensure the product is laid straight. Affix the channel to the surface with the appropriate screws. If installing into a concrete surface, masonry plugs are necessary. For bends and curves, find the appropriate sections where 5cm clips may be installed, and secure them down with screws. Lay the product into the channel with the power plug ends extending from the end of the first piece of channel. Secure with silicone.

##### Mounting Method 2: Routed Channel

Follow the same guidelines as for the Aluminum Channel, but insert into a routed groove in wood or other material or into a groove provided for from a concrete pour.